

What is a TSPD?



ON Semiconductor®

<http://onsemi.com>

TECHNICAL NOTE

The TSPD or Thyristor Surge Protector are specialized silicon based overvoltage protectors, used to protect sensitive electronic circuits from damaging overvoltage transient surges caused by induced lightning and powercross conditions.

The TSPD protects by switching to a low on state voltage when the specified protection voltage is exceeded. This is known as a “crowbar” effect. When an overvoltage occurs, the crowbar device changes from a high-impedance to a low-impedance state. This low-impedance state then offers a path to ground, shunting unwanted surges away from the sensitive circuits.

This crowbar action defines the TSPD’s two states of functionality: Open Circuit and Short Circuit.

Open Circuit – The TSPD must remain transparent during normal circuit operation. The device looks like an open across the two wire line.

Short Circuit – When a transient surge fault exceeds the TSPD protection voltage threshold, the devices switches on, and shorts the transient to ground, safely protecting the circuit.

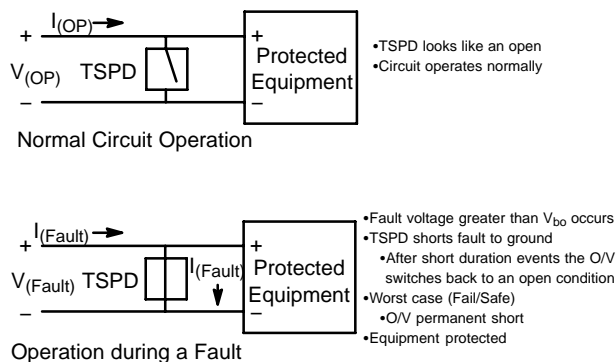

Figure 1. Normal and Fault Conditions

The electrical characteristics of the TSPD help the user to define the protection threshold for the circuit. During the open circuit condition the device must remain transparent; this is defined by the I_{DRM} . The I_{DRM} should be as low as possible. The typical value is less than 5 μ A.

The circuit operating voltage and protection voltage must be understood and considered during circuit design. The $V_{(BO)}$ is the guaranteed maximum voltage that the protected circuit will see, this is also known as the protection voltage. The V_{DRM} is the guaranteed maximum voltage that will keep the TSPD in its normal open circuit state. The TSPD $V_{(BO)}$ is typically a 20–30% higher than the V_{DRM} . Based on these characteristics it is critical to choose devices which have a V_{DRM} higher than the normal circuit operating voltage, and a $V_{(BO)}$ which is less than the failure threshold of the protected equipment circuit. A low on-state voltage V_t allows the TSPD to conduct large amounts of surge current (500 A) in a small package size.

Once a transient surge has passed and the operating voltage and currents have dropped to their normal level the TSPD changes back to its open circuit state.

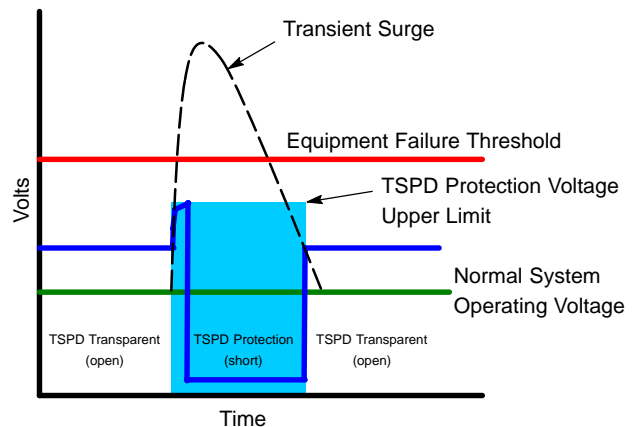

Figure 2. Protection During a Transient Surge

TSPD’s are useful in helping designers meet safety and regulatory standards in Telecom equipment including GR–1089–CORE, ITU–K.20, ITU–K.21, ITU–K.45, FCC Part 68, UL1950, and EN 60950.

ON Semiconductor offers a full range of these products in the NP series product line.

ON Semiconductor and **ON** are registered trademarks of Semiconductor Components Industries, LLC (SCILLC). SCILLC reserves the right to make changes without further notice to any products herein. SCILLC makes no warranty, representation or guarantee regarding the suitability of its products for any particular purpose, nor does SCILLC assume any liability arising out of the application or use of any product or circuit, and specifically disclaims any and all liability, including without limitation special, consequential or incidental damages. "Typical" parameters which may be provided in SCILLC data sheets and/or specifications can and do vary in different applications and actual performance may vary over time. All operating parameters, including "Typicals" must be validated for each customer application by customer's technical experts. SCILLC does not convey any license under its patent rights nor the rights of others. SCILLC products are not designed, intended, or authorized for use as components in systems intended for surgical implant into the body, or other applications intended to support or sustain life, or for any other application in which the failure of the SCILLC product could create a situation where personal injury or death may occur. Should Buyer purchase or use SCILLC products for any such unintended or unauthorized application, Buyer shall indemnify and hold SCILLC and its officers, employees, subsidiaries, affiliates, and distributors harmless against all claims, costs, damages, and expenses, and reasonable attorney fees arising out of, directly or indirectly, any claim of personal injury or death associated with such unintended or unauthorized use, even if such claim alleges that SCILLC was negligent regarding the design or manufacture of the part. SCILLC is an Equal Opportunity/Affirmative Action Employer. This literature is subject to all applicable copyright laws and is not for resale in any manner.

PUBLICATION ORDERING INFORMATION

LITERATURE FULFILLMENT:

Literature Distribution Center for ON Semiconductor
P.O. Box 5163, Denver, Colorado 80217 USA
Phone: 303-675-2175 or 800-344-3860 Toll Free USA/Canada
Fax: 303-675-2176 or 800-344-3867 Toll Free USA/Canada
Email: orderlit@onsemi.com

N. American Technical Support: 800-282-9855 Toll Free
USA/Canada
Europe, Middle East and Africa Technical Support:
Phone: 421 33 790 2910
Japan Customer Focus Center
Phone: 81-3-5773-3850

ON Semiconductor Website: www.onsemi.com
Order Literature: <http://www.onsemi.com/orderlit>
For additional information, please contact your local
Sales Representative